

Mike Berrisford 13/10/11 15:21
Deleted: Annual Quantity BRD v0.5
Mike Berrisford 13/10/11 15:21
Deleted: Annual Quantity BRD

Business Requirements Definition

for

Project Nexus

submitted to

Project Nexus Workgroup Annual Quantity

Author (for this version):	Xoserve
Version:	<u>0.5</u>
Date:	<u>23/09/2011</u>

michele.downes 22/9/11 11:14
Deleted: 4
michele.downes 22/9/11 11:15
Deleted: 08

This document contains confidential or privileged information; it should not be copied or disclosed to any third party without the express permission of Xoserve Ltd. All rights reserved.

Copyright © 2011 Xoserve Ltd

michele.downes 22/9/11 11:15
Deleted: 4

1. Glossary

Term / Acronym	Definition
<u>Annual Quantity (AQ)</u>	<u>Annual quantity of gas assumed to be offtaken over a period based on historical information</u>
AQ Close-Out	The last Day on which Meter Readings or other information received by the Transporters will be considered for the purposes of the Monthly AQ Review.
AQ Effective Day	The Day on which the Notified AQ becomes effective.
Calculated AQ	The AQ calculated as a result of a read being loaded
Consumption Period	The period in Days between the dates of the actual two Meter Readings available for use in the Monthly AQ Review calculations.
Current AQ	The Annual Quantity registered at a Supply Meter Point prior to a change in the Annual Quantity made as a result of the Monthly AQ Review.
End Meter Reading	The later Meter Reading, that is not more recent than the Information Close-Out Day, which determines the end of the Consumption Period.
Monthly AQ Review	The process conducted by the Transporters whereby, as a result of Meter Readings, the Annual Quantity of a Supply Meter Point is recalculated.
Notification Day	The Day on which the Transporters notify the Registered Users of changes in the Annual Quantity.
Notified AQ	The Annual Quantity notified by the Transporters when a change of Annual Quantity of a Supply Meter Point is notified to the Registered User as a result of the Monthly AQ Review.
Optimum Read	An ideal read within the required period to calculate an AQ
Prime and Sub	Is a Sub-deduct Arrangement
Read Validation Override Flag	The indicator set by the User on read submission to request that despite anticipating a Supply Meter Point would fail validation, the meter reading is correct.
Revised AQ	The new AQ calculated
Site	Supply Meter Point level
Start Meter Reading	The earlier Meter Reading that determines the start of the Consumption Period.

michele.downes 23/9/11 12:21

Deleted: 4

Sub-deduct Arrangement	An arrangement of pipes and meters, by which a part of the gas which is conveyed by a System to premises for the purposes of supply to those premises, is further conveyed to other premises for the purposes of supply to those other premises.
Valid Read	A meter reading which has passed all GT read validations as described in the 'Meter Read Submission and Processing and Settlement Arrangements BRD'. <u>For Product 1, 2 or 3, a valid read can be an actual or estimated read and for Product 4 a valid read can be the estimated transfer reading.</u>
Winter Consumption	The consumption of a Supply Meter Point calculated from meter readings taken, over the period 01 December to 31 March,
Winter Annual Ratio (WAR)	The ratio of the Winter Consumption of a Supply Meter Point to its Annual Quantity.

michele.downes 23/9/11 12:21
Deleted: 4

2. Document Purpose

The purpose of this document is to ensure that the business requirements associated with the referenced change have been accurately captured and to clearly specify these requirements to the Project Nexus AQ Workgroup and Project Nexus UNC Workgroup (PN UNC). Adequate information should be provided to enable the industry to approve the documented requirements for Cost benefit Analysis at a later stage.

The contents refer to the business scope of the change and provide descriptions of the business requirements and the relevant existing and future process maps.

This version of the document contains draft business rules for the different options identified by the AQ Workgroup regarding AQ processes. These options have been documented for further discussion and clarification at the Workgroup.

2.1. Intended Audience

- Gas Shippers/Suppliers
- Gas Transporters
- Xoserve
- Customer Representative

michele.downes 23/9/11 12:21

Deleted: 4

3. Executive Summary

3.1 Introduction to the change

This document defines the timescales and processes associated with the calculation of the Annual Quantity for all directly connected gas meter points.

The document has been based on presentations and discussions at the Project Nexus AQ Workgroup and considering the high level principles agreed at the AQ Principle Workgroup in April 2010. The options have been documented for further discussion and clarification. All areas within the document are yet to be agreed and finalised.

All square brackets [] indicates values that can be parameterised for the purposes of the BRD although will require confirming for system design or system design or system development. The **highlighted text** represents areas for clarification which must be resolved by the Workgroup prior to the business rules being finalised.

3.2 Implementation Timescales

Implementation of the developed solution will be confirmed once all requirements are captured following the Project Nexus Requirements Definition Phase.

3.3 Change Drivers and Business Goals

3.3.1 Drivers

The drivers detailed below are those identified by the AQ Workgroup for the derivation of the Annual Quantity (AQ);

- AQ to accurately reflect site consumption
- To utilise the reads obtained from remotely read meters in the calculation of the AQ
- To simplify the process wherever possible without affecting the accuracy of the AQ
- To systematise processes
- To smooth out workloads throughout the year
- Provide an incentive to Shippers to submit accurate and timely reads
- Provide transparency throughout the AQ review process and via industry reports

3.3.2 Business Goals

To develop a robust regime for the derivation of a site's annual consumption (AQ) that is utilised in downstream processes. The AQ to be as accurate as possible using the latest available historic meter reads.

michele.downes 23/9/11 12:21
Deleted: 4

3.4 Change Background

The changes have been identified as a result of Xoserve’s Project Nexus consultation for the replacement of UKLink systems and following DECC’s consultation on Smart metering and Supplier licence obligation for the installation of advanced meters.

The changes are also as a result of Modification 0209 which was allocated to the Project Nexus Workgroup in May 2009 and more recently Modification 0380 which is a replacement for Mod 0209.

3.4.1 Areas Identified in the Initial Requirements Register (IRR)

- Introduction of a rolling AQ is a core services required to ensure energy is accurately allocated
- Rolling AQ will reduce the risk to RbD shippers and their costs associated with reconciliation
- Increased energy consumption data should feed into an updated AQ rather than waiting for the annual review
- Rolling AQ being developed by Mod 0209 workgroup and should feature in Project Nexus
- Review of the SOQ for DM and NDM sites throughout the year as currently it can be up to 12 months out of date

3.4.2 Business process Issues raised during the Workgroups

- Changes in consumption are not immediately reflected in the AQ
- Current AQ is based on historic consumption data, the AQ does not accurately reflect current consumption
- Unable to appeal SSP AQs
- Manually labour intensive during the summer months for all parties
- Impacts on other processes during the processing and updating of the AQ
- Current process does not provide an incentive to submit reads more frequently

3.4.3 UNC and Licence Impacts

3.4.4 UNC Process Impacts

3.4.5 Interaction with Project Nexus High Level Principles

michele.downes 23/9/11 12:21
Deleted: 4

In April 2010 the following high level principles for an AQ review were agreed at the Project Nexus Principle Workgroup;

- Preference for a 'No AQ' regime. This regime is only possible where daily allocations are performed based on actual reads.
 - However, it was recognised that an AQ will continue to be required for UNC processes, industry processes and licence obligations. GTs would also require an AQ for network operations.
- Transitional arrangements in a 'No AQ' regime would use a 'Rolling AQ' principle.
- 'Rolling AQ' was the preferred option where allocations were not performed daily using actual reads.
- Fallback position was an improved Annual AQ review.

3.5 Related Documents

Document Title	Location
Modification 0209: Rolling AQ	Joint Office Website
Modification 0380: Periodic AQ Calculation	Joint Office Website
AQ Principles Workgroup Report (19/05/2010)	Joint Office Website
Meter Read Submission and Processing and Settlement Arrangements BRD	Joint Office Website
PN UNC Workgroups	Joint Office Website

michele.downes 23/9/11 12:21
Deleted: 4

4. Benefits

4.1 Industry Benefits

The following benefits will need to be aligned with the Transporter relevant objectives;

- Site AQ will more accurately reflect site consumption
- Utilising the reads received from remotely read meters
- More accurate allocations
- Simplified Shipper and GT processes
- Spread out workload
- Incentivise more frequent read submission

5. Change Scope

5.1 In Scope

Function:

- Calculation of a site's AQ
- Timing of the calculation
- Validation of the AQ
- Submission of the AQ to Shippers
- Challenges to the AQ
- Updating the AQ
- SOQ, SHQ and BSSOQ calculation and timing of the calculation

Market Sector:

- All directly connected gas meter points
- Daily Metered CSEP sites
- NTS sites
- Prime and Sub sites
- NDM CSEPs (aspiration for all iGT sites to be treated the same as directly connected sites)

5.2 Out of Scope

Function:

- Any process not described above as In Scope

Market Sector:

- None identified

michele.downes 23/9/11 12:21

Deleted: 4

Detailed Requirements Analysis

6. Assumptions and Concerns

6.1 Assumptions

- The business rules will need to be appropriate for dumb metered sites as well as remotely read sites
- The processes described in the Settlement Workgroups are approved
- The proposed validations carried out by the GT at read receipt will ensure that any significant erroneous reads are rejected and not used for AQ calculation.
- Only the latest replaced valid read at the time the AQ is calculated will be used.
- Ratchets will continue as an incentive regime where Shippers nominate the SOQ and SHQ.
- There will not be a requirement to retrospectively update the AQ.
- If 'Monthly Rolling AQ Review' is implemented prior to the 4 Processes determined in the Settlement Workgroup, the current UNC read limits would continue to apply.
- An AQ will not be calculated if the validations on the read have failed due to asset data
- Estimated reads will not be used for Product 4 sites except estimated transfer reads.
- Sub deduct arrangements will continue and the Prime and Sub-deduct meter(s) will continue to have an AQ for each meter (currently the AQ for the Sub-deduct meter is deducted prior to calculating the Prime meter AQ).
- AQ process during a 'Leap Year' will be treated the same as the current arrangements, i.e. calculate 365+1 daily consumptions.
- Threshold Crosser adjustments, Mod 0640, will not be required where rolling AQ is implemented with or after individual Meter Point Reconciliation. If the business rules described in this document are implemented before Meter Point Reconciliation Mod 0640 adjustments may need to continue (see Section 9) until Meter Point Rec is implemented.

michele.downes 27/9/11 11:05

Deleted: However, if the read is 'flagged' by the Shipper as correct the read will bypass tolerance check validations and will be used for reviewing and updating the AQ.

michele.downes 28/9/11 12:09

Deleted:

6.2 Dependencies

- The processes described within the Settlement Workgroup are unchanged.
- The GT read validations described under the 'Meter Read Submission and Processing and Settlement Arrangements BRD' would need to be implemented before the rules described in this document are implemented.
- Approval of the requirements by PN UNC
- Approval by Ofgem following the appropriate UNC Modification process.

6.3 Risks & Issues

michele.downes 23/9/11 12:21

Deleted: 4

- Not all Shippers/Suppliers attend the workgroups or are represented therefore there may be opposition to any potential Modifications raised.
- If the monthly AQ regime were implemented before the read validations described under the Settlement regime, interim/transitional arrangements may need to be applied to ensure erroneous AQs are not implemented as a result of an invalid read being loaded.
- Impacts on allocation will continue if the AQ is not calculated due to incorrect asset data held on the Supply Point Register as a new AQ will not be calculated.

michele.downes 28/9/11 12:10
Deleted: .

michele.downes 28/9/11 12:10
Deleted: <#>Issues .

6.4 Constraints

6.5 Design Considerations

- For Product 1 and 2 sites it is not essential for the AQ to be reviewed monthly as the AQ is not used for critical processes e.g. allocations and energy balancing. A monthly AQ review for these sites was agreed by the workgroup for consistency reasons; all sites receive a monthly AQ review.

6.6 Concerns

- Ofgem have raised concerns regarding the submission of estimates by Shippers as this can provide an opportunity for gaming, for example by submitting over or understated estimated reads depending on the SAP rates. However, it was agreed by the Workgroup that all estimated reads will be calculated using a standard methodology.

michele.downes 23/9/11 12:21
Deleted: 4

Mike Berrisford 13/10/11 15:21
 Deleted: Annual Quantity BRD v0.5
 Mike Berrisford 13/10/11 15:21
 Deleted: Annual Quantity BRD

7. Overview of Business Processes

7.1 Current Processes and Process Maps

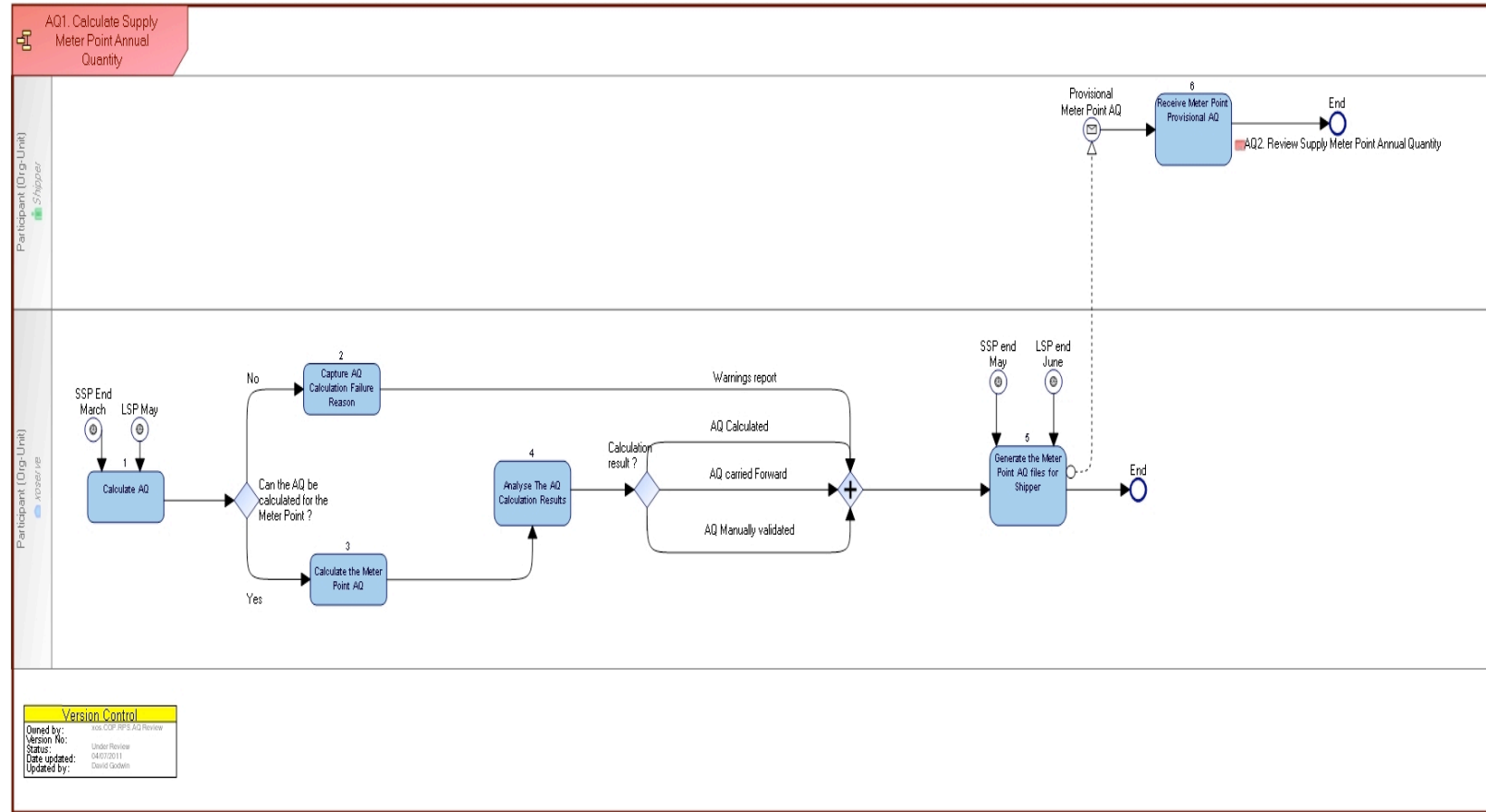

Michael Downes 22/9/11 11:15
 Deleted: 4

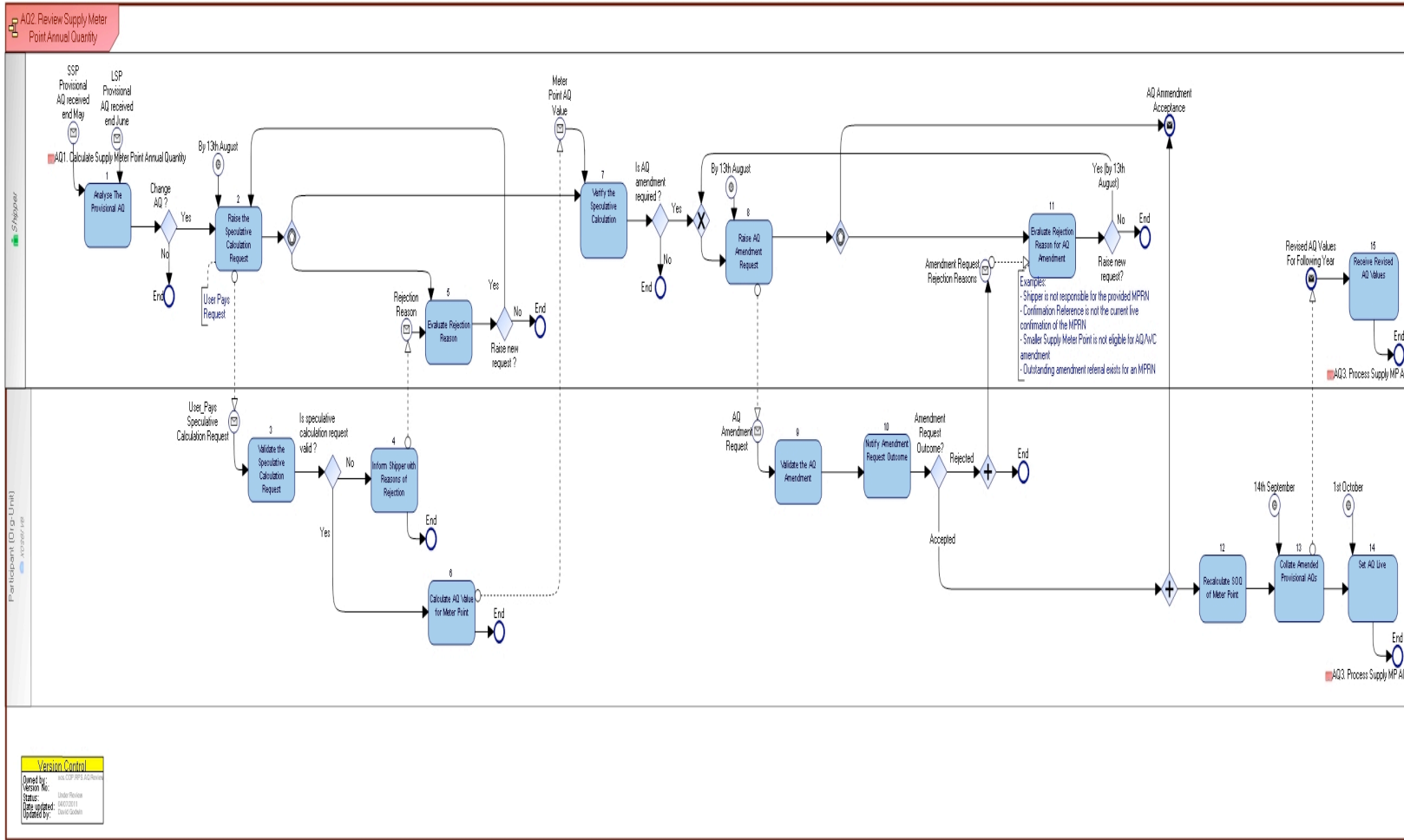

michele.downes 23/9/11 12:21
Deleted: 4

**AQ3 Process Supply MP
AQ Revision Appeal**

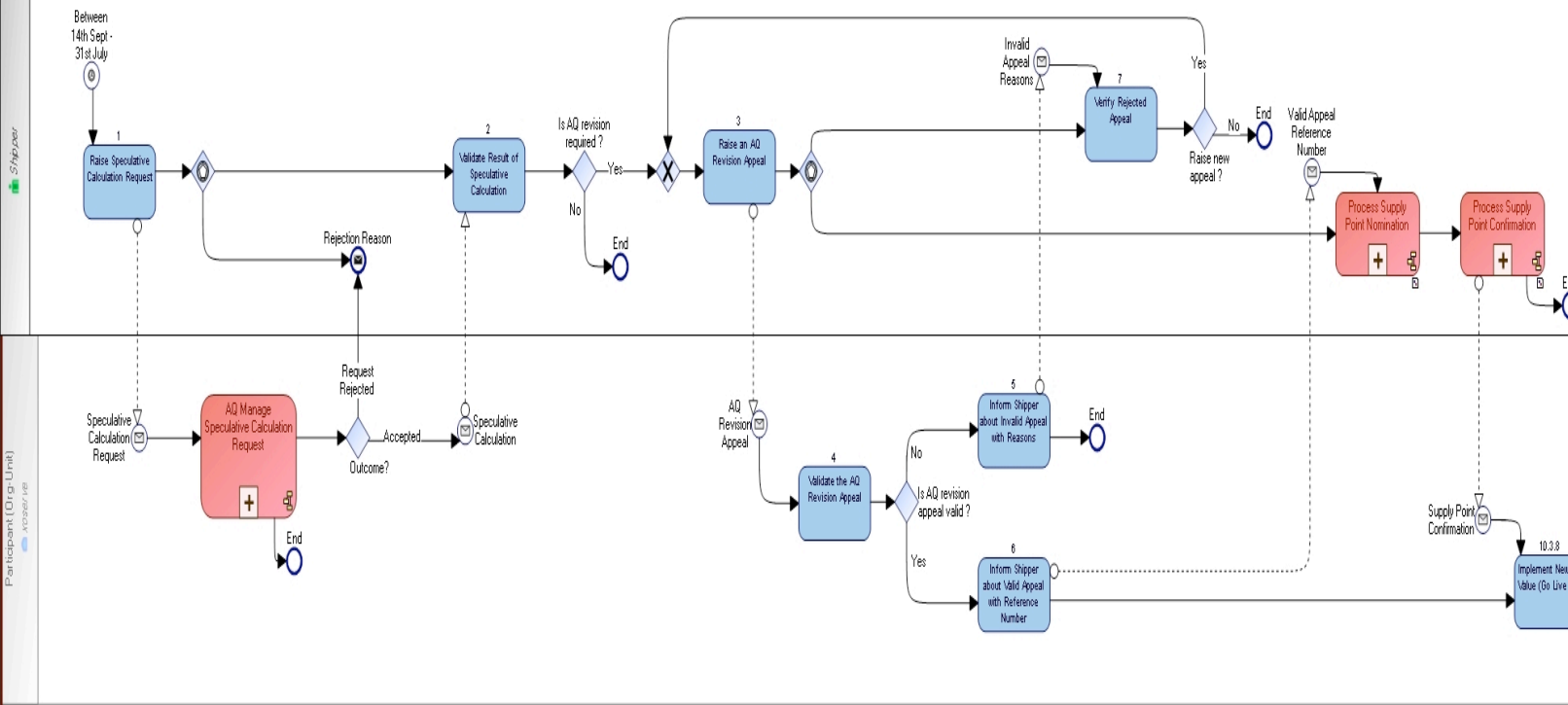

Participant (Org Unit)
Shipper
xserve

Version Control	
Owned by:	isis COP RPS AQ Review
Version No:	
Status:	Under Review
Date updated:	30/09/2011
Updated by:	David Godwin

nes 23/9/11 12:21

Deleted: 4

AQ4. Review Supply Meter Point BSSQ, UWP

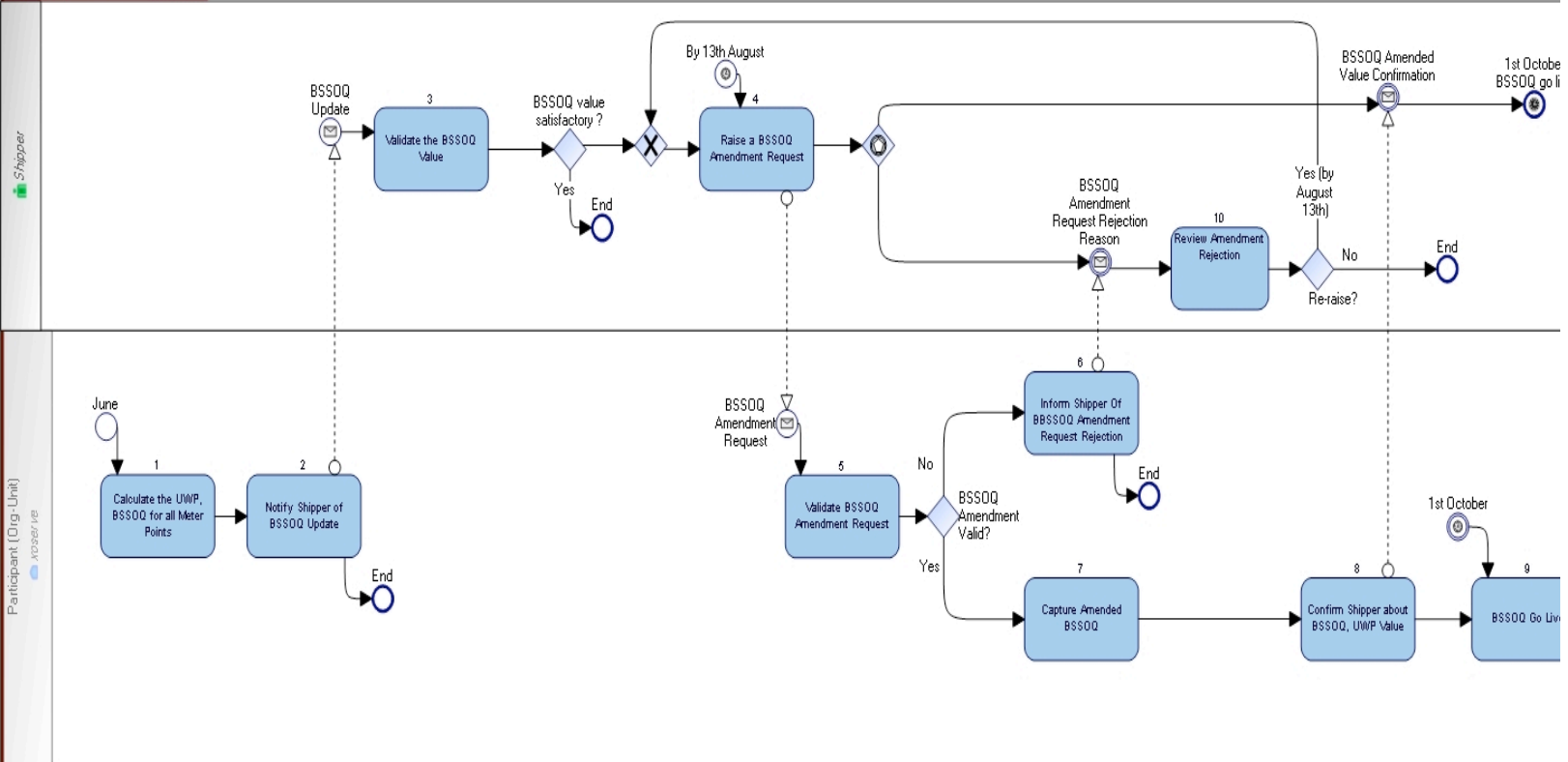

Version Control	
Owned by:	xxx, COP, FRS, AQ Review
Version No:	Under Review
Status:	04/07/2011
Date updated:	David Godwin
Updated by:	

nes 23/9/11 12:21

Deleted: 4

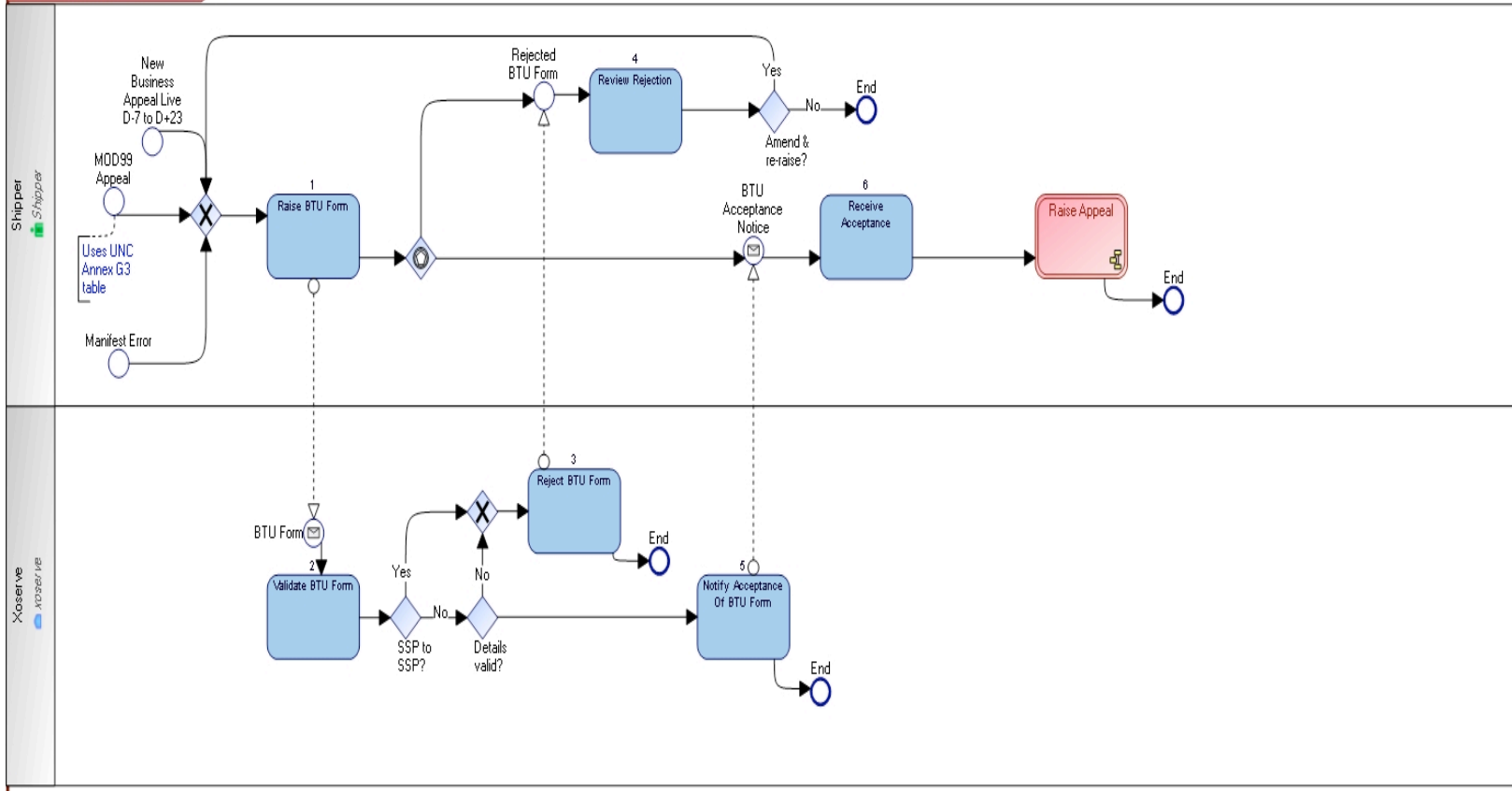

Michere Downes 23/9/11 12:21
Deleted: 4

7.2 To-Be Processes and Process Maps

michele.downes 29/9/11 15:00

Deleted: .

michele.downes 23/9/11 12:21

Deleted: 4

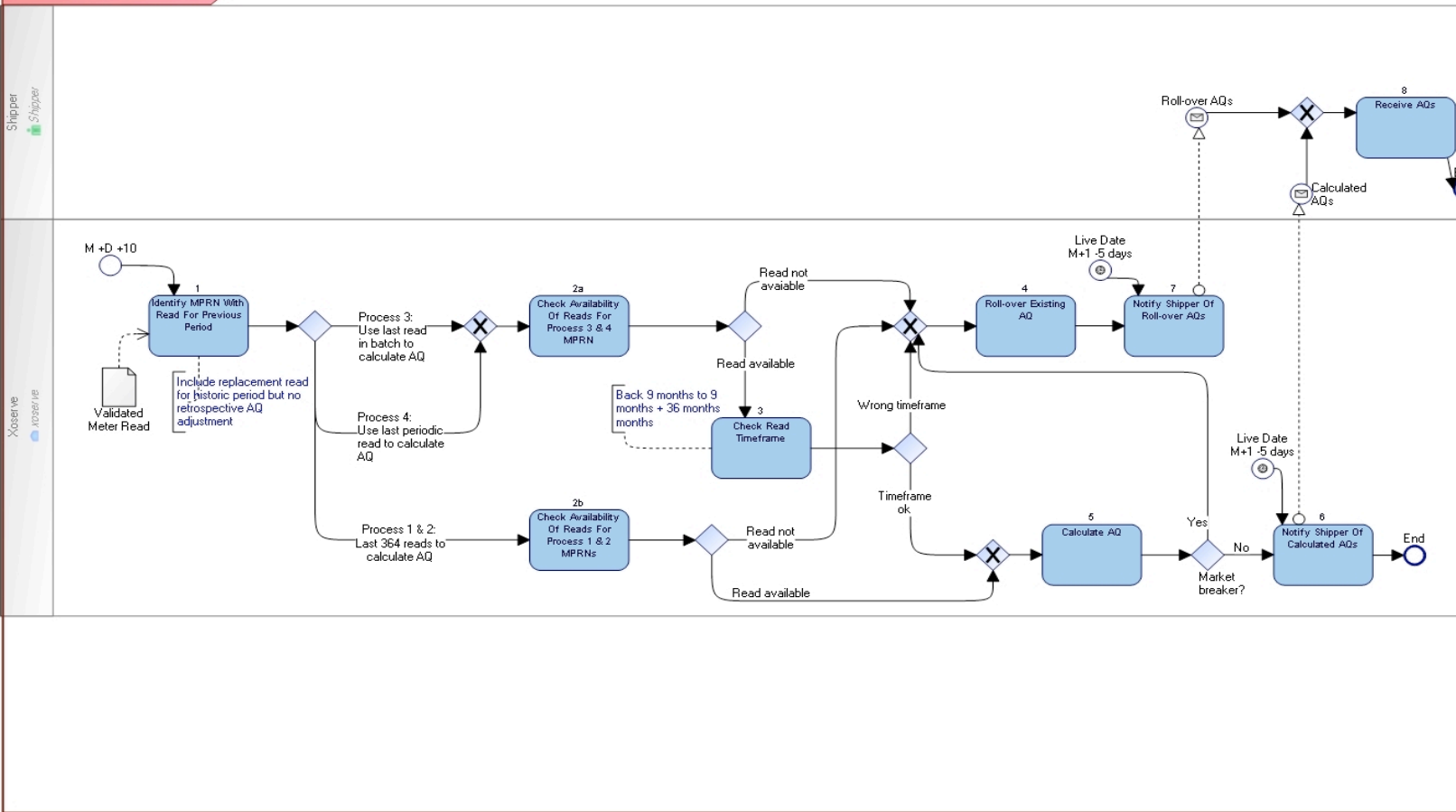

7

michele.downes 29/9/11 15:34
Deleted: .

michele.downes 23/9/11 12:21
Deleted: 4

Mike Berrisford 13/10/11 15:21
 Deleted: Annual Quantity BRD v0.5
 Mike Berrisford 13/10/11 15:21
 Deleted: Annual Quantity BRD

8. Business Requirements

Throughout this section reference is made to four new processes designed in the Project Nexus Settlement Workgroup for the submission and processing of meter readings and settlement arrangements. These four future state processes are summarised below;

- Product 1, 'Daily Metered Time Critical'
 - Daily reads obtained and submitted to the GT daily before 10.00 am on GFD+1.
 - Actual or estimated reads may be submitted by the Shipper. Estimates to be provided in accordance with standard industry methodology.
 - The latest valid read loaded will be used for allocation and energy balancing purposes.

- Product 2, 'Daily Metered Not Time Critical'
 - Daily reads obtained and submitted to the GT daily.
 - If the reads are submitted before 10.00 am they will be used for allocation purposes otherwise a read must be received before end of the GFD+1.
 - Actual or estimated reads may be submitted by the Shipper. Estimates to be provided in accordance with standard industry methodology.
 - The latest valid read loaded by GFD+5 will be used for final allocation and energy balancing purposes.

- Product 3, 'Batched Daily Readings'
 - Daily readings are obtained for each day but are not submitted daily
 - The daily reads are received in batches to a pre-notified frequency
 - Actual or estimated reads may be submitted within the batch by the Shipper. Estimates to be provided in accordance with standard industry methodology.
 - Reconciliation will be carried out based on the valid daily reads received
 - Allocation and energy balancing is based on the estimate calculated by the GT.

- Product 4; 'Periodic Readings'
 - An actual meter reading is submitted periodically.
 - Allocation and energy balancing is based on the estimate calculated by the GT.
 - Reconciliation is carried out using the methodology determined within the Reconciliation Workgroup

Figure 1 provides a summary of the AQ processes by Settlement Product;

michele.downes 29/9/11 12:28
 Deleted: cess

michele.downes 22/9/11 11:15
 Deleted: 4

Mike Berrisford 13/10/11 15:21
Deleted: Annual Quantity BRD v0.5
 Mike Berrisford 13/10/11 15:21
Deleted: Annual Quantity BRD

Figure 1: Summary of the 4 meter reading processes and related AQ processes

Process Description	Read Used for Allocation	Read used for Energy Balancing	Shipper Read Submission	Timing of AQ calculation	Reads used for AQ calculation	Read Type used for the AQ calculation	SOQ Calculation	Reconciliation
1: Daily Metered Time Critical Readings	Daily Read	Daily Read	Daily by 10 am on GFD+1	Monthly	Daily Reads (last 365)	Actual & Shipper Estimate	Shipper Nominates	Meter Point level following a re-synch or estimate
2: Daily Metered not Time Critical Readings	GT Estimate	Daily Read	Daily by end of GFD+1	Monthly	Daily Reads (last 365)	Actual & Shipper Estimate	Shipper Nominates	Meter Point level following a re-synch or estimate
3: Batched Daily Readings	GT Estimate	GT Estimate	Daily Reads in Batches	Monthly	2 reads a minimum of 9 months & max of 36 months apart	Actual & Shipper Estimate	GT Derives	Daily Rec at Meter Point level on receipt of a batch of reads
4: Periodic Readings	GT Estimate	GT Estimate	Periodically	Monthly	2 reads a minimum of 9 months & max of 36 months apart	Actual	GT Derives	Meter Point level at receipt of read

michele.downes 22/9/11 11:15
Deleted: 4

8.1 Meter Reads

- 8.1.1 All valid meter readings will be considered for use in the AQ review, including the transfer read. If the read has been loaded it is deemed as valid for the purposes of the Monthly AQ Calculation.
- 8.1.2 For Product 1, 2 and 3 sites; actual and estimated meter readings will be considered for use in the AQ calculation.
- 8.1.3 For Product 4 sites; only actual meter readings will be considered for AQ calculations
- 8.1.4 The latest valid read loaded at AQ Close Out will be used to trigger the AQ calculation. Both estimated and actual reads will be used to calculate the AQ for sites in Product 1, 2 and 3.

8.2 Monthly Process

- 8.2.1 The AQ review will take place monthly for all sites where a read has been loaded by the 10th business day of the month (AQ Close Out). Where a valid read has not been loaded the current AQ will continue until a valid read is loaded.
- 8.2.2 The AQ calculation will use;
- 8.2.3 Sites within Product 1 or 2; the latest read and the previous 364 daily reads.
- 8.2.4 Sites within Product 3 or 4; the latest valid read (as per 8.1.2 and 8.1.3) to determine the End Meter Reading and a valid Start Meter Reading obtained from a minimum period of 9 calendar months previous and a maximum period of 36 months.
- 8.2.5 The Shipper will be notified of the revised AQ no later than 5 business days prior to the end of the month (Notification Day).
- 8.2.6 The Revised AQ will become effective on the 1st day of the month following the AQ Notification Day.

michele.downes 27/9/11 14:46
Deleted: actual

michele.downes 27/9/11 14:49
Deleted: n

michele.downes 27/9/11 14:49
Deleted: end

michele.downes 27/9/11 14:49
Deleted: r

michele.downes 27/9/11 14:50
Deleted: at least

8.3 Consumption Periods

- 8.3.1 For Product 1 and 2 sites the AQ will be calculated from the consumptions taken from the latest valid meter reading and the previous 364 days daily meter readings.
- 8.3.2 For Product 3 and 4 sites the AQ will be calculated using a consumption period of;

michele.downes 23/9/11 12:21
Deleted: 4

- At least 9 months from the Start Meter Reading to the End Meter Reading
 - Maximum of 36 months to the Start Meter Reading or last Seasonal Normal Demand Review (SND) date (SND updates WAALP factors retrospectively for a 3 year period. WAALP factors are used to calculate AQ.)
- 8.3.3 For Product 3 and 4, the optimum consumption period from the start and end valid meter readings available is;
- For sites with a Meter Reading Frequency of Weekly, Fortnightly or Monthly read: a consumption period closest to 50 weeks
 - For sites with a Meter Reading Frequency of Quarterly, 6 Monthly or Annually read: a consumption period closest to 42 weeks
- 8.3.4 If an 'Optimum Read' as per 8.3.3 is not available the system will;
1. Obtain a valid read for an older date upto a maximum of 36 months, if no read available
 2. Obtain a valid read for a more recent date upto a minimum of 9 months
- 8.3.5 If the Meter Point has been isolated during the Consumption Period and the Start and End Meter readings are equal to or greater than 9 months, an AQ will be calculated. An AQ will not be calculated if the consumption period is less than 9 months where the Meter Point has been isolated during the Consumption Period.
- 8.3.6 Where none of the conditions set out in 8.3.1 to 8.3.5 can be satisfied the Current AQ will continue to apply and the Shipper will be notified

- michele.downes 3/10/11 14:10
Deleted: s
- michele.downes 3/10/11 14:10
Deleted: m
- michele.downes 3/10/11 14:10
Deleted: r
- michele.downes 3/10/11 14:10
Deleted: e
- michele.downes 3/10/11 14:10
Deleted: m
- michele.downes 3/10/11 14:10
Deleted: r
- michele.downes 3/10/11 14:10
Deleted: end
- michele.downes 3/10/11 14:11
Deleted: m
- michele.downes 3/10/11 14:11
Deleted: r
- michele.downes 27/9/11 15:31
Deleted: f
- michele.downes 27/9/11 15:32
Deleted: read sites:
- michele.downes 3/10/11 13:57
Deleted: sites
- michele.downes 27/9/11 15:35
Deleted:
- michele.downes 27/9/11 15:36
Deleted: i

8.4 Validation

- 8.4.1 An AQ will not be calculated for the reasons described under Section 8.4.7.
- 8.4.2 Where an AQ is calculated the GT will not perform validation on the AQ before submission to the Shipper as meter reads will be validated by the GT on receipt of the read, this is described in the 'Meter Read Submission and Processing and Settlement Arrangements BRD'.
- 8.4.3 Where an incorrect AQ is calculated as a result of a read being loaded the Shipper can submit a new read within the timescales described under Section 8.2 and a new AQ will be calculated and be effective, subject to validation, for the 1st of the following month.
- 8.4.4 There will not be a retrospective adjustment to energy or transportation charges where the AQ calculated is later found to be incorrect.
- 8.4.5 Where the calculated AQ is less than 1 kWh (value will be rounded to 1) or = to 1 kWh the current AQ will be carried over and the Shipper notified.
- 8.4.6 Where the Calculated AQ is the same as the current AQ the Calculated AQ will be the Revised AQ.

- michele.downes 29/9/11 14:45
Deleted: 6
- michele.downes 27/9/11 15:41
Deleted: . M

- michele.downes 23/9/11 12:19
Deleted: 4

8.4.7 A Revised AQ will not be calculated for the following reasons. Where an AQ is not calculated, the current AQ will apply and the Shipper will be advised;

- A more recent End Meter Reading is not available than that used previously to successfully determine the Notified AQ;
- From the meter readings available, a Consumption Period of greater than 9 months can not be established.
- From the meter readings available, a Consumption Period of less than or equal to three years can not be established.
- For Products 1 and 2, where 365 daily consumptions are not available and an Optimum Read described in Section 8.14 can not be obtained.
- Insufficient data to calculate an AQ (e.g. new Supply Meter Point)

Note: Further validations may be identified during the detailed analysis of the requirements.

8.5 Read Validation Override Flag

8.5.1 On the read submission communication a field will be included for the Shipper to notify and warrant to the GT that the read for the MPRN will fail the read tolerance checks (as described in the 'Meter Read Submission and Processing and Settlement Arrangements BRD') but confirms that the read is correct, has been validated and should be accepted and processed by the GT. Note this warrant will not allow a read to pass through the "market breaker" validation.

8.5.2 The Validation Override Flag is a request by the Shipper for the GT to bypass the read tolerance checks (as described in the 'Meter Read Submission and Processing and Settlement Arrangements BRD') only.

8.5.3 Note: Checks will continue to be carried out on the asset data and where the standing data provided by the Shipper on the read communication does not match the data held on the Supply Point Register (as per existing validations) the read will be rejected and not used for AQ calculation. If the checks on the asset data are correct the read will be used to calculate the AQ as per the timescales described under Section 8.2.

michele.downes 28/9/11 10:42

Deleted: validations

michele.downes 28/9/11 12:20

Deleted: and

michele.downes 28/9/11 12:20

Deleted: v

michele.downes 28/9/11 10:46

Deleted: will be

8.6 AQ Correction

8.6.1 This is an exception process to amend the AQ in certain circumstances. This process is not to be used for 'normal' AQ increases or decreases whereby the submission of reads will update the AQ over time. This process can only be used for the following reasons:

michele.downes 22/9/11 11:18

Deleted: A

michele.downes 22/9/11 11:22

Deleted: that

michele.downes 23/9/11 12:19

Deleted: 4

- on the basis of substantial evidence that available reads do not represent actual consumption of gas (e.g. new business, confirmed theft of gas)
- because of a change in the consumer's equipment which results in an expected change in gas consumption
- for the avoidance of doubt, vacant sites are excluded from this exceptions process.

8.6.2 Checks will be carried out to ensure the conditions described under 8.6.1 have been complied with, those that fail will be rejected and the Shipper notified.

8.6.3 An AQ Correction can be raised at any time during the year and for any site subject to 8.6.1.

8.6.4 The Shipper notifies the GT of the revised AQ (Shippers reasonable estimate of the site's AQ), a pair of actual meter readings (if available) and the reason for the change in AQ.

8.6.5 GT will consider the information and notify the Shipper within [X] business days of the outcome of the consideration.

8.6.6 Where the AQ Correction request is valid, the AQ will be included in the monthly process timescales described under Section 8.2 (Note: a valid read will not have been loaded to trigger the AQ review therefore this may require the GT to load a read in order for the Meter Point to be included in the monthly AQ review.

8.6.7 The Shipper will record and retain all evidence in support of the AQ Correction request and provide it to the GT when requesting a change.

8.6.8 Any rejected requests will be notified to the Shipper together with the reasons for rejection and the Current AQ will apply.

8.6.9 The Current AQ will continue to apply until the AQ Correction has been accepted as valid by the GT and the new AQ is effective.

8.6.10 If the GT receives further Meter Readings that better meet the criteria set out in Section 8.3 than those submitted by the Shipper, the Notified AQ will be calculated from these Meter Readings.

michele.downes 28/9/11 12:22
Comment: Do we need to describe the conditions, e.g. NBA must be between X and X days of the Confirmation?

8.7 Thresholds

8.7.1 Where the Revised AQ of a Meter Point is greater than 58,600,000 kWh for 3 consecutive calculations of the AQ or for 3 calculations in the preceding [6] month period, but is not already classified as a DM mandatory site and within Product 1, the Daily Read Requirement will apply with effect from [6] months after the Effective date when the AQ first reached the DM Mandatory threshold.

michele.downes 28/9/11 11:03
Deleted: s

8.8 Supply Point Offtake Quantity (SOQ)

michele.downes 23/9/11 12:19
Deleted: 4

8.8.1 The Shipper will continue to nominate the site SOQ and SHQ for Product 1 and 2 sites only.

8.8.2 The existing process for the GT deriving the SOQ will continue for Product 3 and 4 sites. The SOQ will be calculated xxx by the GT and reviewed as per current timescales.

8.9 WAR Bands and EUCs

8.9.1 The WAR bands and applicable EUCs will be updated in line with the AQ.

8.9.2 The AQ will reflect any Meter Point cross-over in WAR bands from the 1st day of the month following the AQ Notification day.

8.10 Prime and Sub-deduct Meters

8.10.1 Except for the requirement described under Section 8.10.3, the existing arrangements for Sub-deduct Arrangements will continue to apply as per UNC G1.8.

8.10.2 The requirement to obtain meter readings within a 5 day window will continue to apply as per UNC G1.8.4 for all Prime and Sub-deduct meters in the same configuration.

8.10.3 Except for Prime or Sub-deduct meters which meet the DM Mandatory threshold, all Prime and Sub-deduct meters in the same configuration shall be processed under the same 'Product' (as per the 'Meter Read Submission and Processing and Settlement Arrangements BRD') and have the same Meter Reading Frequency.

8.11 Other Parameter Changes

8.11.1 Following a revision to the Seasonal Normal Composite Weather Variables, the AQ and SOQs will be revised at the first Notification Day following the update in Weighted Average Annual Load Profile.

8.12 Bottom Stop SOQ (BSSOQ)

8.12.1 The existing arrangements will apply for the application and calculation of the BSSOQ annually.

8.12.2 BSSOQ will only apply to Product 1 and Product 2 sites.

michele.downes 23/9/11 12:19
Deleted: 4

8.13 AQ Communication

8.13.1 A notification will be issued to the Shipper of all Revised AQs. The communication will include;

- MPRN
- Current AQ
- Current EUC & EUC Description
- Current WAR band
- Revised AQ
- Revised EUC & EUC Description
- Revised WAR Band
- Effective date
- Start Meter Reading & Date
- End Meter Reading & Date
- Prorated Winter Consumption (Prorated WC over the optimum winter period, potentially used to derive EUC), when & where applicable
- Percentage AQ Change
- BSSOQ (when & where applicable)

8.13.2 A notification will be issued to the Shipper of all AQs that have not been calculated. The communication will include;

- MPRN
- Revised AQ (if applicable)
- Rejection Reason (if applicable)
- Reason why a revised AQ was not calculated (if applicable)
- Current AQ value rolled over
- Current EUC & EUC Description
- Current WAR band
- Rejected AQ
- Rejected EUC & EUC Description
- Rejected WAR Band
- Start Meter Reading & Date
- End Meter Reading & Date
- Prorated Winter Consumption (Prorated WC over the optimum winter period, potentially used to derive EUC) (when & where applicable)
- Rejected BSSOQ (when & where applicable)

8.13.3 The above notifications will be issued separately.

8.14 Regime Transfer

For site transfers between Products where non daily read sites may transfer to daily read and vice versa, the following rules will apply for the calculation of the AQ. These rules apply irrespective of whether there is a change of Shipper or not.

michele.downes 28/9/11 12:24
Deleted: or have failed the AQ validation

steve.j.nunnington 29/9/11 14:42
Deleted: if

steve.j.nunnington 29/9/11 14:42
Deleted: is also

michele.downes 28/9/11 11:11
Deleted: in Shipper

steve.j.nunnington 29/9/11 14:42
Deleted: or no

michele.downes 28/9/11 11:11
Deleted: there is no

steve.j.nunnington 29/9/11 14:42
Deleted: change in

steve.j.nunnington 29/9/11 14:43
Deleted:

michele.downes 23/9/11 12:19
Deleted: 4

8.14.1 Transfer from Product 1 or 2 to Product 3 or 4

- As daily reads are available the requirement to obtain an Optimum **Read** is achievable.
- At the first AQ review following the transfer an Optimum Read to be obtained for the relevant consumption period, i.e. 42 or 50 weeks depending on the Meter Reading Frequency.

michele.downes 3/10/11 14:13
Deleted: r

8.14.2 Transfer from Product 3 to Product 1 or 2

- As daily reads are **already** available the requirement to obtain 365 daily reads is achievable.
- At the first AQ review following the transfer, if a batch of reads has not been loaded the current AQ will apply. The current AQ will continue to apply until the batch of reads previous to the transfer has been loaded and the AQ based on 365 reads can be calculated.

8.14.3 Transfer from Product 3 to Product 4

- As daily reads will be available an Optimum **Read** to be obtained at 42 or 50 weeks, depending on the Meter Reading Frequency.

michele.downes 3/10/11 14:13
Deleted: r

8.14.4 Transfer from Product 4 to Product 1 or 2

- As daily reads will not be available an Optimum **Read at 50 weeks shall be sourced to calculate the AQ. This will continue until 365 reads are available to calculate the AQ.**

michele.downes 3/10/11 14:13
Deleted: r

michele.downes 27/9/11 14:44
Deleted: 42

8.14.5 Transfer from Product 4 to Product 3

- Optimum read to be obtained at 42 or 50 weeks, depending on the Meter **Reading Frequency.**

michele.downes 3/10/11 14:13
Deleted: r

8.14.6 Transfer between Product 1 or 2

- As daily reads are available the requirement to obtain 365 daily reads is achievable.

michele.downes 3/10/11 14:13
Deleted: f

8.15 Publication of Information

michele.downes 23/9/11 12:19
Deleted: 4

8.15.1 The data items listed under 8.15.2 are likely to be required for industry reporting. This is not a complete list, the reports will be defined once existing Modifications around AQ reporting are completed which will provide the Workgroup with reporting principles and the scope of the reports based on decisions made within the Modification Workgroups.

8.15.2 Data items required for industry reports include, but is not limited to:

- No. of MPR's by Shipper by Product where a new AQ calculated has been & Revised
- No. of MPR's by Shipper by Product where a new AQ calculated has not been calculated
- % of portfolio
- Sum of current AQ
- Sum of Revised AQ
- Total of MPR's rejected by Rejection Reason
- Total MPR's where AQ amended via the AQ Correction process
- Total no. of AQ increases by Shipper
- Total no. of AQ decreases by Shipper

michele.downes 23/9/11 12:19

Deleted: 4

9. Transitional Rules

Transitional rules are required to deal with the period immediately prior to and following the implementation of these rules.

9.1 Implementation Date

The workgroup do not believe there are any process or system restrictions for when a rolling AQ regime can be implemented however this may change following detailed analysis of the requirements.

michele.downes 23/9/11 13:42
Deleted: re are no

If an annual review is not carried out before the rolling AQ process is implemented there may be an issue with some MPRs not having their AQ reviewed until the next valid read is loaded which could be as long as 2 years (assuming a read is obtained as a result of the Must Read obligation)

9.2 Threshold Crosser Adjustments

Current Modification 0640 Threshold Crosser Adjustments will not be required if the Rolling AQ processes are implemented with or after Meter Point Reconciliation. If Rolling AQ is implemented before Meter Point Reconciliation the Mod 0640 adjustments will need to continue. Further discussion and analysis will be required if this is the case.

michele.downes 23/9/11 12:19
Deleted: 4

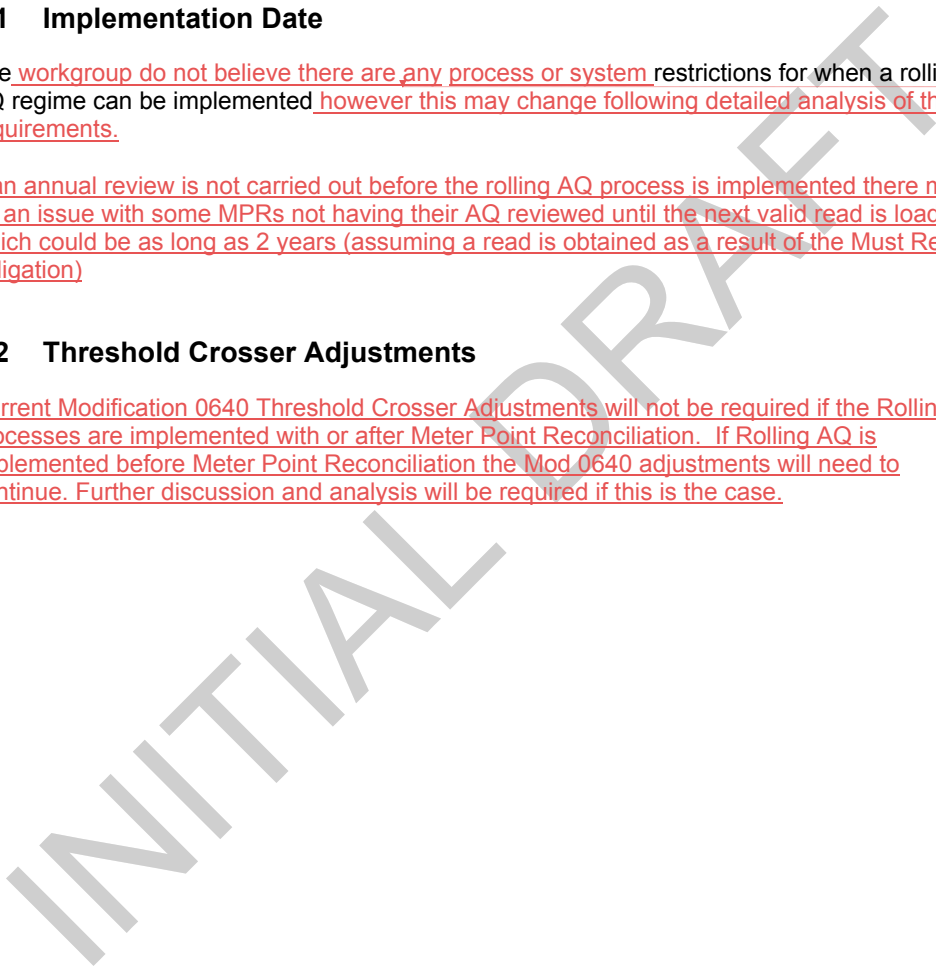

10. Non-Functional Business Requirements

INITIAL DRAFT

michele.downes 23/9/11 12:19

Deleted: 4

11. Appendices

INITIAL DRAFT

michele.downes 23/9/11 12:19
Deleted: 4

12. Document Control

Version History

Version	Status	Date	Author(s)	Summary of Changes
0.1	Initial Draft	05/07/2011	Xoserve	First draft
0.2	Draft	19/07/2011	Xoserve	Updated following PN UNC Workgroup meeting on 18/07/2011
0.3	Draft	16/08/2011	Xoserve	Updated following PN UNC Workgroup on 03/08/2011
0.4	Draft	08/09/2011	Xoserve	Updated following PN UNC Workgroup on 06/09/2011
<u>0.5</u>	<u>Draft</u>	<u>23/09/2011</u>	<u>Xoserve</u>	<u>Updated following PN UNC Workgroup on 20/09/2011</u>

Reviewers

Name	Version	Date
AMR Workgroup attendees		

Approval

Name	Role	Date
AMR Workgroup		
PN UNC		

michele.downes 23/9/11 12:19
Deleted: 4