



respect > commitment > teamwork

# Billing & Invoicing End to End Process Walkthrough

25<sup>th</sup> November

An information only call out.

Denotes a change in the process.

A BRD reference.

 File Changes – No change

 File Changes - Minor

 File Changes - Medium

 File Changes – Major

 File Changes - New

**xserve**



respect > commitment > teamwork

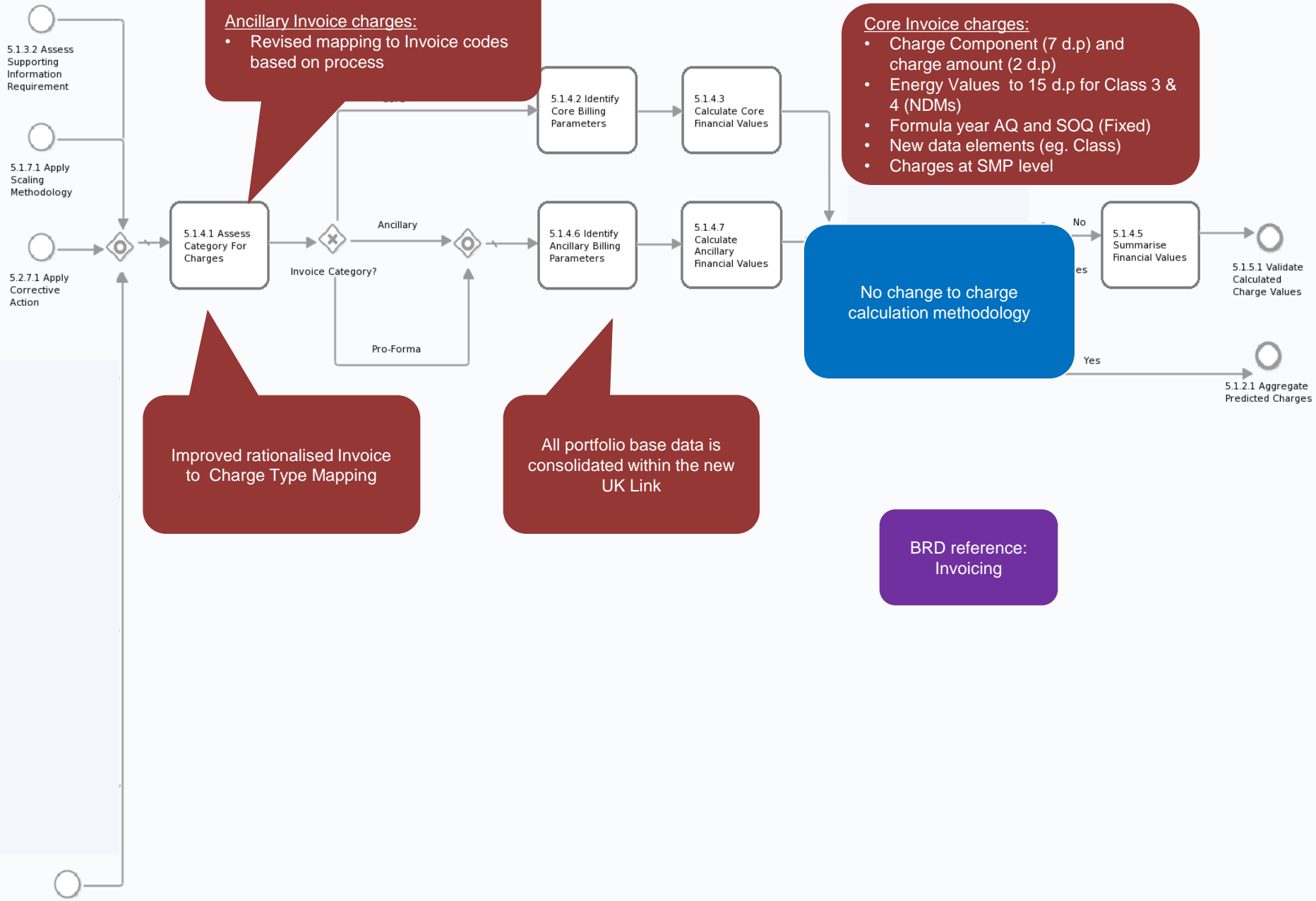

Xoserve

# Perform Reconciliation Scaling Adjustment

## RbD Smear for LSP:

- Continues for 12 months (transition)
- Annual advancing pot

- Post 'Go-Live' the LDZ insignificant errors and LDZ energy adjustments will be fed to UG smear
- LDZ Significant measurement errors will be apportioned over the error period. Pre-go live ,error period will be apportioned based on the SSP market share and post go live will be based on shipper's throughput position post go live date

The prevailing position for the shipper each month will be revised based on the reconciliations locked down from the latest amendments invoice (GRE) for the 12 months period

5.1.6.3 Validate Calculated

5.1.7.1 Apply Scaling Methodology

5.1.2 Create Prevailing Throughput Position

[Next Billing Period]

5.1.6.1 Identify LDZ Scaling Adjustment Base Data

UNC reference:  
Sec E  
MOD 432/473

BRD reference:  
Reconciliation Sec 6.2.5

## New UG smear for LSP & SSP:

- Starts from Go live date
- No transportation charges, only energy (GRE)
- Monthly variances will be created to assist apportionment

## UG Smear Input:

- Locked down GRE values (£ and kWh) from latest Rec invoice
- Actual throughput values for shippers within an LDZ
- Allocation factors

## UG Smear output:

- Apportioned GRE amount and kWh per shipper per LDZ per smear month

## Transition period:

- The LSP reconciliations pre Go live - **RbD pot**
- The LSP/SSP reconciliations post Go live - **new UG smear pot**
- There will not be any reconciliations billed for SSPs prior to Go live date
- All reconciliations will take place at meter point level post Go live date

5.1.4.1 Assess Category For Charges

There are no changes to the Invoicing principles

- Introduction of
- Generic Invoice file (.INV)
  - Additional supporting information for Core invoices (Class 3 & 4) at SMP level
  - VAT category – VA, VE, VZ
  - Rationalised Invoice type codes
  - Invoice Number will be made to 12 digits

Invoicing BRD reference:  
Sec S

Xoserve

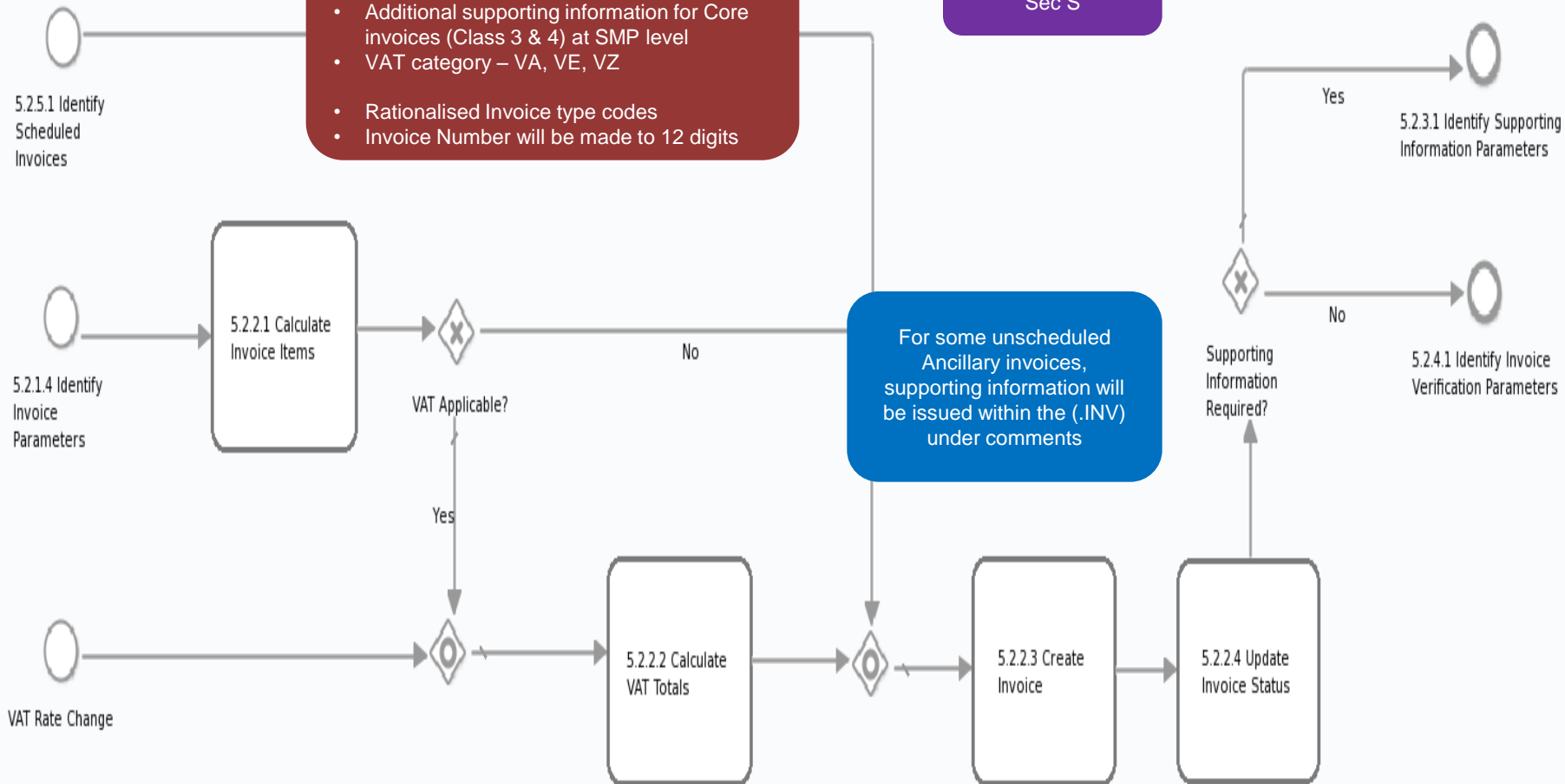

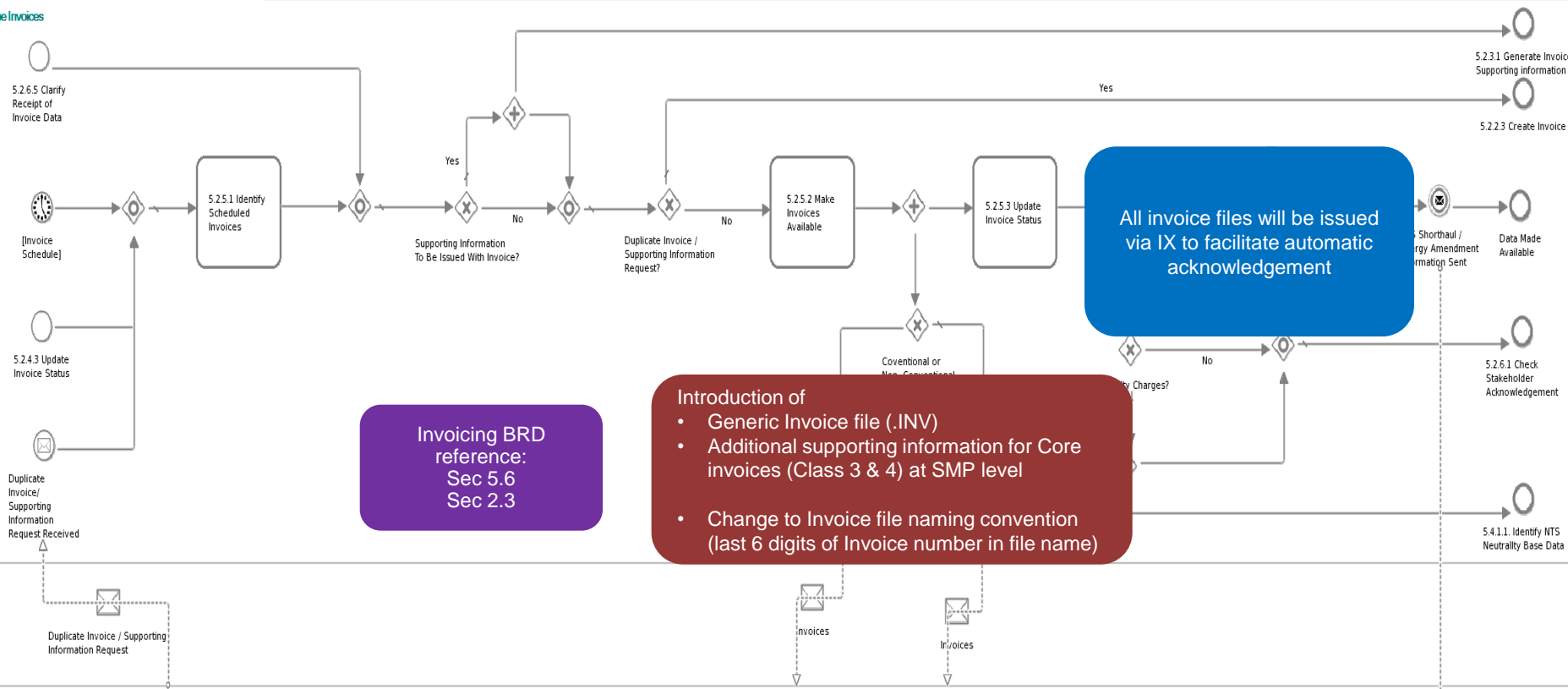

Invoicing BRD reference:  
Sec 5.6  
Sec 2.3

Introduction of

- Generic Invoice file (.INV)
- Additional supporting information for Core invoices (Class 3 & 4) at SMP level
- Change to Invoice file naming convention (last 6 digits of Invoice number in file name)

Generic Invoice file

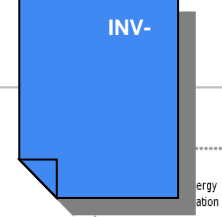

File Changes – No change
File Changes – Minor
File Changes – Medium
File Changes – Major
File Changes – New

# Generate Invoice Supporting Information

