

# xserve



respect > commitment > teamwork

## SMIP – UKL Committee

13 December 2012

# Agenda

- Background
- Effective Switching
  - Outline of proposed solution
  - Fast track implementation
    - Pre-empt analysis conclusion
    - Approach to subsequent findings
  - Approvals
- Mandatory Switching
  - High level view of solutions

# SMIP Phases

- Ofgem Effective Switching Initiative Jan 2013
  - Suppliers must inform customers of any changes to functionality they may experience following CoS.
  - Installing supplier has an obligation to provide comms links to the Smart Meter
- DCC Go Active Q3 2013
  - DCC and its service providers can charge potential DCC users.
- Smart Switching becomes Standard Q3 2013
  - When a SM is fitted the supplier cannot exchange it for a dumb meter
- DCC Go Live Q3 2014
  - DCC becomes the single licensed entity providing comms links with domestic SMs in the UK.

# Items currently held on UK Link

- Meter Point Reference Number (MPRN)
- Supplier ID
- Supplier Effective From Date
- MAM ID
- MAM EFD
- Meter Point Address
- Meter Point Postcode
- Market Sector Flag

# Registration Data Items - New

- Source Registration SystemID
- Supplier ETD
- Meter Mech Code (Modified)
- SMSO
- SMSO EFD
- DCC Service Status Flag
- DCC Service Status Flag EFD
- IHD Install Status
- IHD Install Status EFD
- UPRN
- Network Owner ID EFD

# Items required Daily by DCC

- Source Registration System ID
- Meter Point Reference Number (MPRN)
- Supplier ID
- Supplier Effective From Date
- Supplier Effective To Date
- MAM ID
- MAM Effective From Date
- Meter Point Address
- Meter Point Postcode
- UPRN
- Network Owner ID
- Network Owner EFD
- Market Sector Flag

# xserve



respect > commitment > teamwork

## Effective Switching

# Foundation Stage

## Ofgem's Effective Switching Initiative

- Where a change of supplier is about to happen the customer must be informed of any smart meter functionality they may lose with their new supplier.
- When a supplier installs a SM they must inform the customer that they may lose functionality if they change supplier.
- Suppliers must delete their information from the SM before they lose the site to another supplier.
- Following a switch a customer should not be charged if the supplier has to exchange the meter to maintain pre-payment functionality.
- When a supplier is about to lose a site he must provide information to the incoming supplier regarding whether or not a smart meter is fitted and just what is the functionality of that meter.

**xserve**



respect > commitment > teamwork



# Foundation Stage

## Ofgem's Effective Switching Initiative

- Similarly the old supplier must provide information to the new supplier to allow them to maintain smart functionality.
- The installing supplier of the meter has to provide services to the incoming supplier following CoS to ensure that smart functionality is maintained.
- The terms of the license conditions mean that only the big six suppliers have to provide these facilities. Smaller suppliers will be exempt until they are well into Smart rollout and by that time DCC should exist.
- These license conditions become effective on 1 January 2013
- Xoserve's solution will be delivered ASAP after that date.

# Effective Switching Stage High Level Requirements

- Provision of Data for CoS
  - Shippers require enquiry or reporting access to determine per MPRN
    - Meter Mech Code Value
    - Installing Supplier
  - Shippers would like a **long term solution** which includes the data items on recognised industry file flows.
- Data Capture
  - Meter Mech Codes provided by shipper/supplier
    - Smart Metering Equipment Technical Specification – SMETS1 and 2 (AVs: S1; S2)
    - Or not SMETS Compliant (AV: NS).
  - Installing supplier derived by Xoserve systems
    - i.e For Meter Mech Codes NS, S1, S2 record the supplier on the date that the corresponding meter was installed.
  - Xoserve stores these values against the affected MPRNs
  - Data Enquiry Service will be enabled to view these data items
  - Xoserve will store these data items on behalf of iGTs

# Effective Switching –

## Meter Mechanism – Additional Allowable Values

- Meter Mechanism Code
  - Amendment required to allow additional allowable values
  - Sample:
    - DEFINITION: The coded value of the description of the Meter Mechanism.
    - ALLOWABLE VALUES: CR -Credit, MT -Mechanical Token, ET - Electronic Token, CM -Coin, PP -Prepayment, TH -Thrift, U - Unknown.
    - ADDITIONAL ALLOWABLE VALUES: NS – Non SMETS Smart Meter, S1 – SMETS 1 Smart Meter, S2 – SMETS 2 Smart Meter
  - Systems will be configured to allow up to S9 as allowable values
    - once formally introduced as an allowable value.

# Effective Switching –

## Meter Mechanism – User to Transporter Notification

- Meter Mechanism Code Input Flows
  - Amendment required to allow additional allowable values in RGMA ‘METER’ Dataset
  - Allowable on ONJOB and ONUPD flows
    - Will be used to derive ‘Installing Supplier’
- Payment Method Code in ‘ASSET’ dataset
  - SPAA change proposes change to this
  - Will remain as ‘GTX’ – i.e. Transporters shall not record this data

# Effective Switching –

## Meter Mechanism – Transporter to User Notification

- Meter Mechanism Code Input Flows
  - Longer term aspiration to incorporate into ‘recognised industry flows’
    - Meter\_Mechanism field is present in a number of different records:
      - S75
      - U06 / N90
      - M03
    - These records are provided in a number of different contexts:
      - S75 – NMR, CFR, TRF
      - U06 / N90 – MRI / PAC
      - M03 – MBR
  - **NB: Detailed analysis phase has not concluded – additional flows may be identified**

**Xserve**



respect > commitment > teamwork

# Effective Switching – Meter Mechanism – Transporter to User Notification

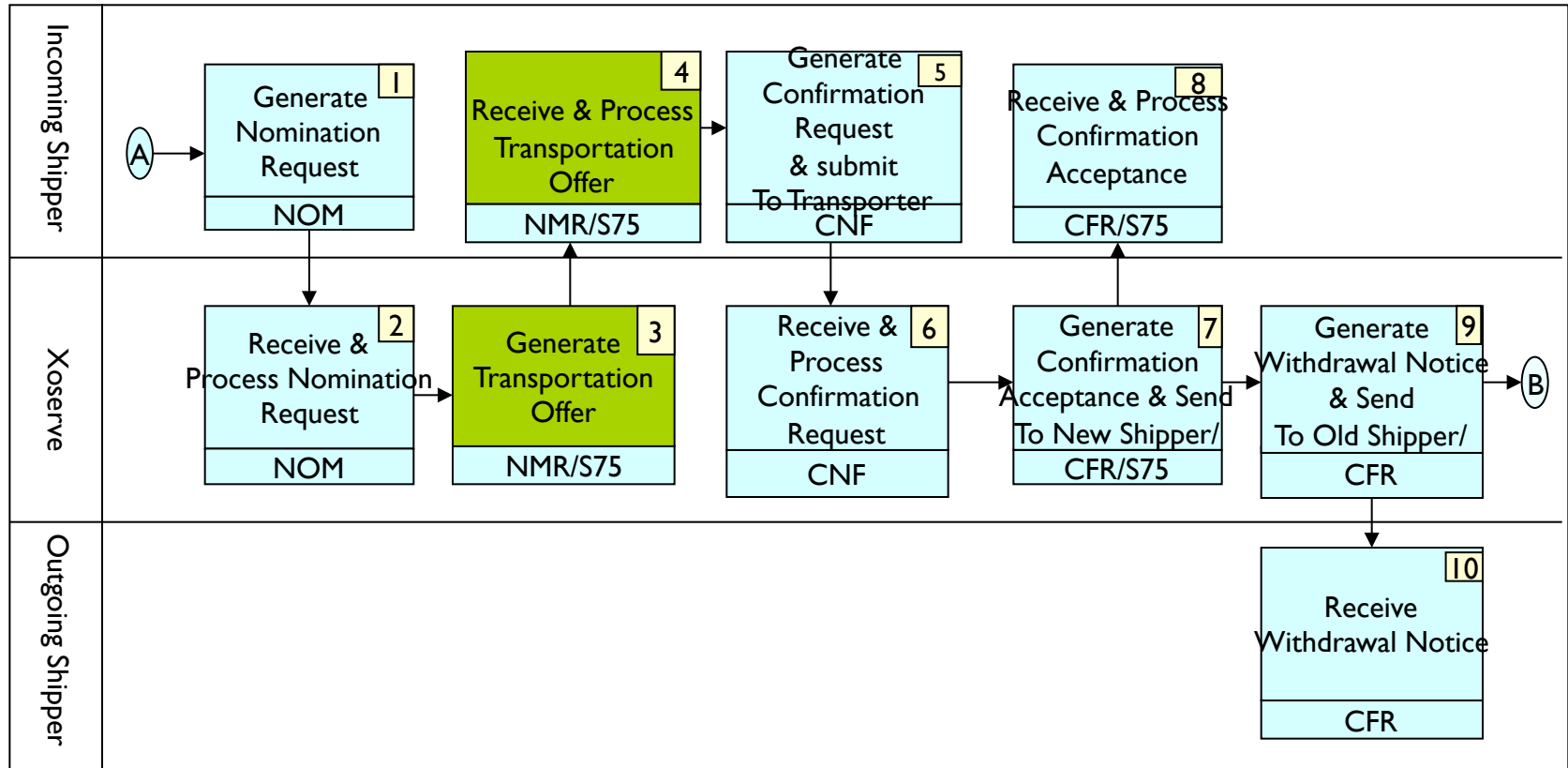

D-6 months max

D-30 to D-15  
D-8 if current Shipper has Withdrawn

# Effective Switching – Meter Mechanism – Transporter to User Notification

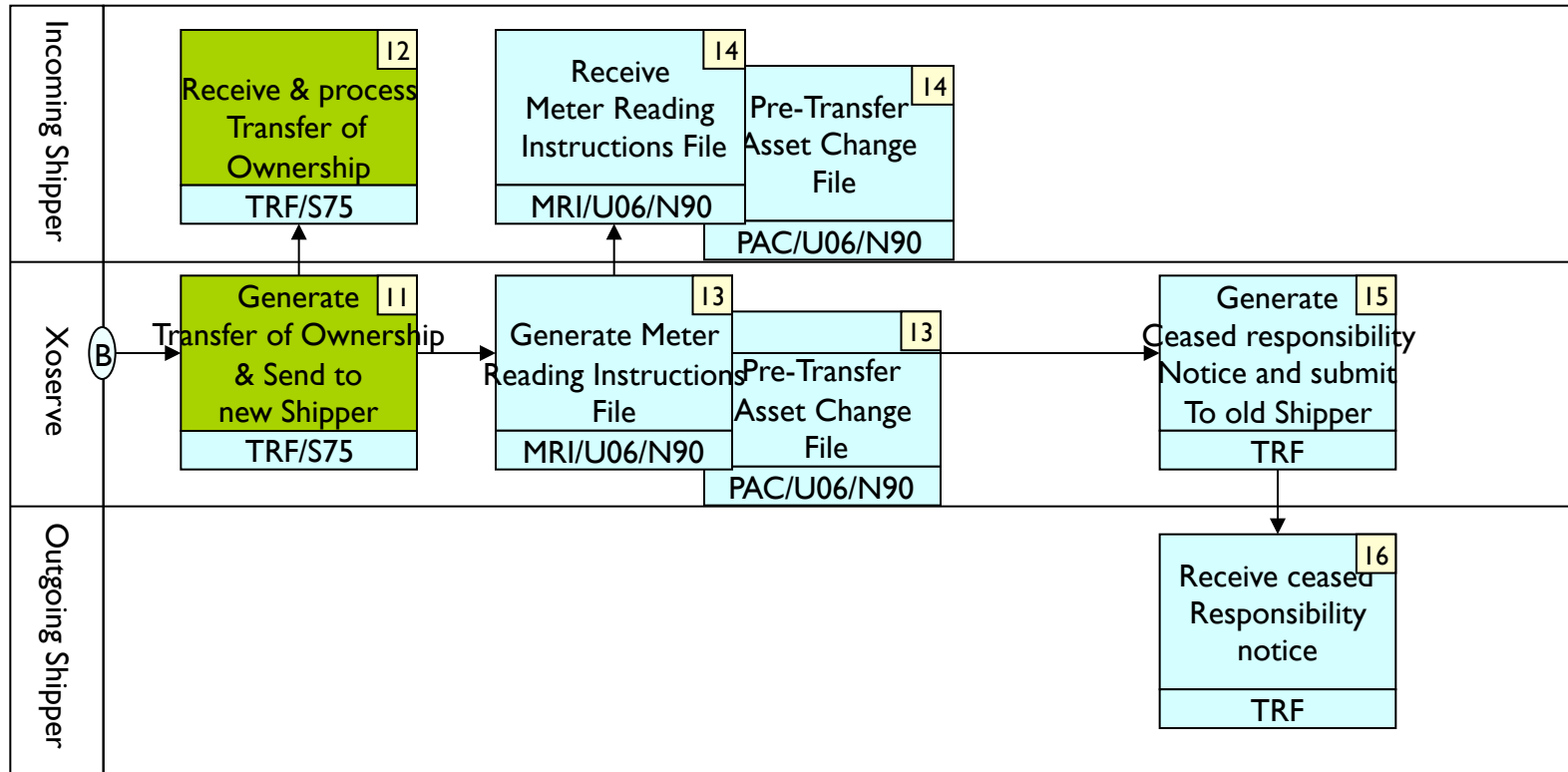

D-7 – no further transfer activity can take place

D – day of transfer

# Effective Switching – Installing Supplier

- Installing Supplier (IS)
  - Will be derived based on ‘Installation Date’
    - ONJOB – Notification of Physical Asset Work
    - ONUPD – Update flows\*\*\*
      - \*\*\* Use of this flow to derive this data MAY result in incorrect ‘Installing Supplier’ derivation where actual IS has failed to update this data correctly
    - No manual exception / update process is proposed
    - Installing Supplier will not be reset if Meter Mech code changes to a dumb code.
    - Installing Supplier will only reset when a meter is removed or exchanged



# Effective Switching – Changes to Data Enquiry

- Meter Mechanism
  - New AVs **only** proposed to be visible in DE Community View
    - Existing Meter\_Mechanism Values will NOT be visible
    - Does this need to be protected in the same manner as Current and Previous Supplier – e.g. tick box
- Installing Supplier (IS)
  - Will be displayed on Community View as derived
    - Does this need to be protected? – e.g. tick box

# Effective Switching - Approval

- UKLC Approval sought on:
  - Meter Mech Codes
    - Input
    - Output
    - Display on DE
  - Installing Supplier
    - Approach and derivation
    - Display on DE

**xserve**



respect > commitment > teamwork

# Effective Switching

- Detailed analysis has not concluded
- IF further changes are identified, these will be highlighted to UKLC, we will try to:
  - Provide ‘appropriate’ representation windows
  - May need to call UKLC parties together for ‘extraordinary UKLC’

**xserve**



respect > commitment > teamwork

# xserve



respect > commitment > teamwork

## Mandatory Smart Switching

# Foundation Stage

## Smart Switching Becomes Mandatory

- Smart Meters cannot be exchanged for Dumb Meters from Q3 2013.
- DECC have requested Xoserve & iGTs to capture and report on 3 data items to support suppliers on CoS
  - Meter Type – Utilising Meter Mech Code
  - Installing Supplier
  - Smart Metering System Operator
    - The entity who communicates with the SM and passes info to and from the supplier.
    - Expected to be an informal role
    - May be captured via RGMA flows

# Foundation Stage Process

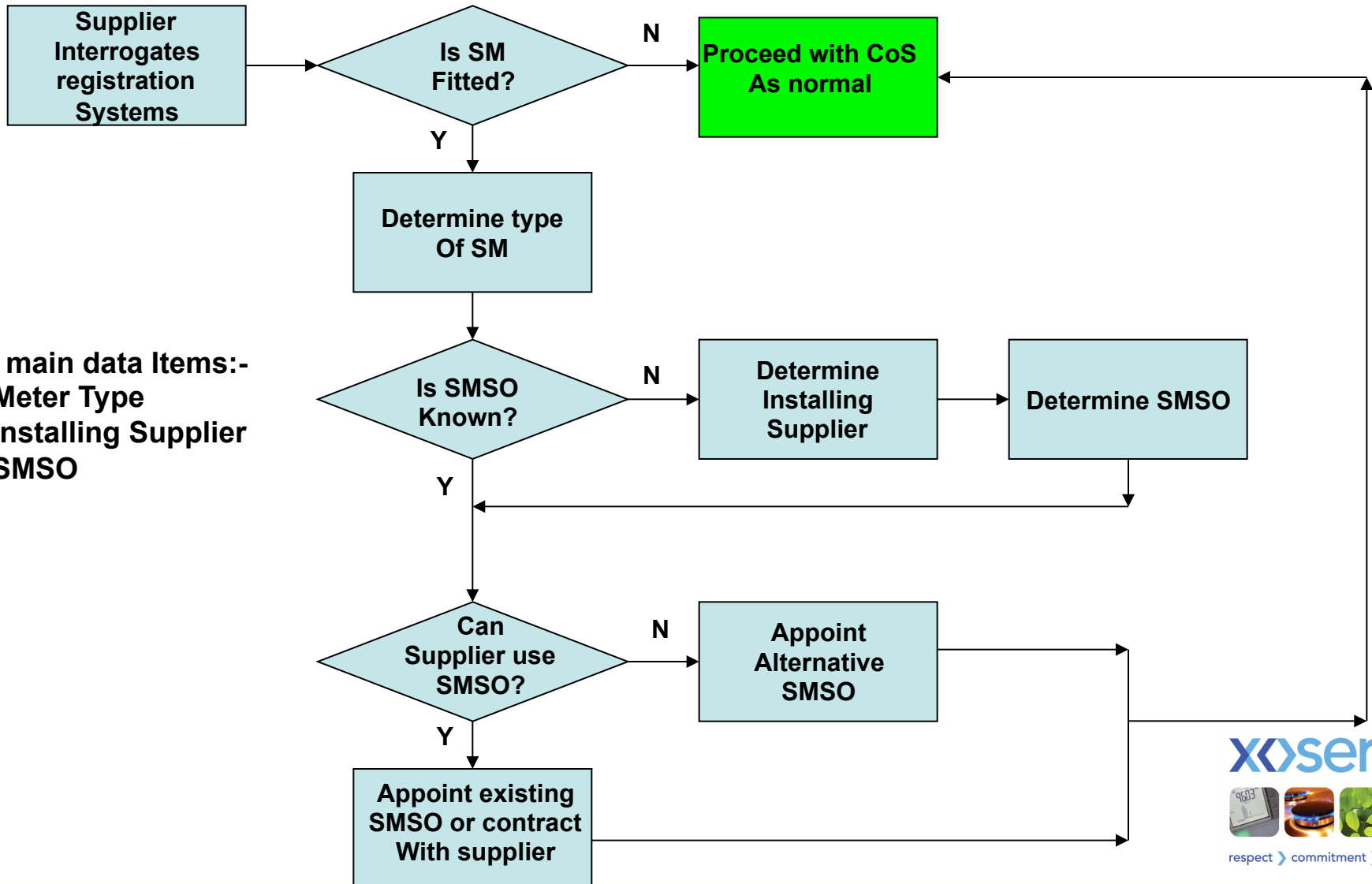

# Mandatory Switching – Changes to Flows

- Changes required to UKL Systems
  - Smart Metering System Operator Id to be received
    - Options – being assessed – For example:
      - Amendments to K08 Record
      - Generic Entity Amendment Mechanism
        - » Enables removal of SUN
        - » Enables transition from MAM
  - Installing Supplier - No change
    - Not passed on CoS flows
    - Visible on DE
  - Meter Mechanism – No change
    - Passed on CoS flows as above
    - Visible on DE

**xserve**



respect > commitment > teamwork

# Key Milestones

Milestone	Date
1 <sup>st</sup> SMETS EU Notification Complete	Q2 2012
Ofgem Effective Switching Initiative	Q1 2013
DCC Licence Award (DCC GO Active)	Q2 2013
DSP & CSP Contacts Awarded	Q2 2013
2 <sup>nd</sup> SMETS EU Notification Complete	Q3 2013
Smart Change of Supplier Becomes Standard	Q3 2013
Start of DCC Industry Trials	Q2 2014
Start of Mass Rollout / DCC Go-Live	Q3 2014

serve



respect > commitment > teamwork