



respect > commitment > teamwork

# MOD455S Work Group

22<sup>nd</sup> August 2013

David Addison / Steve Deery

- **Revised Process Flow**
- **Sample SSP Statistics**
- **Other Data Volumetrics that may support inconsistent data information**
  - **Rejected Meter Readings**
  - **RGMA Rejections**

**xserve**



respect > commitment > teamwork

# Revised Process Flow

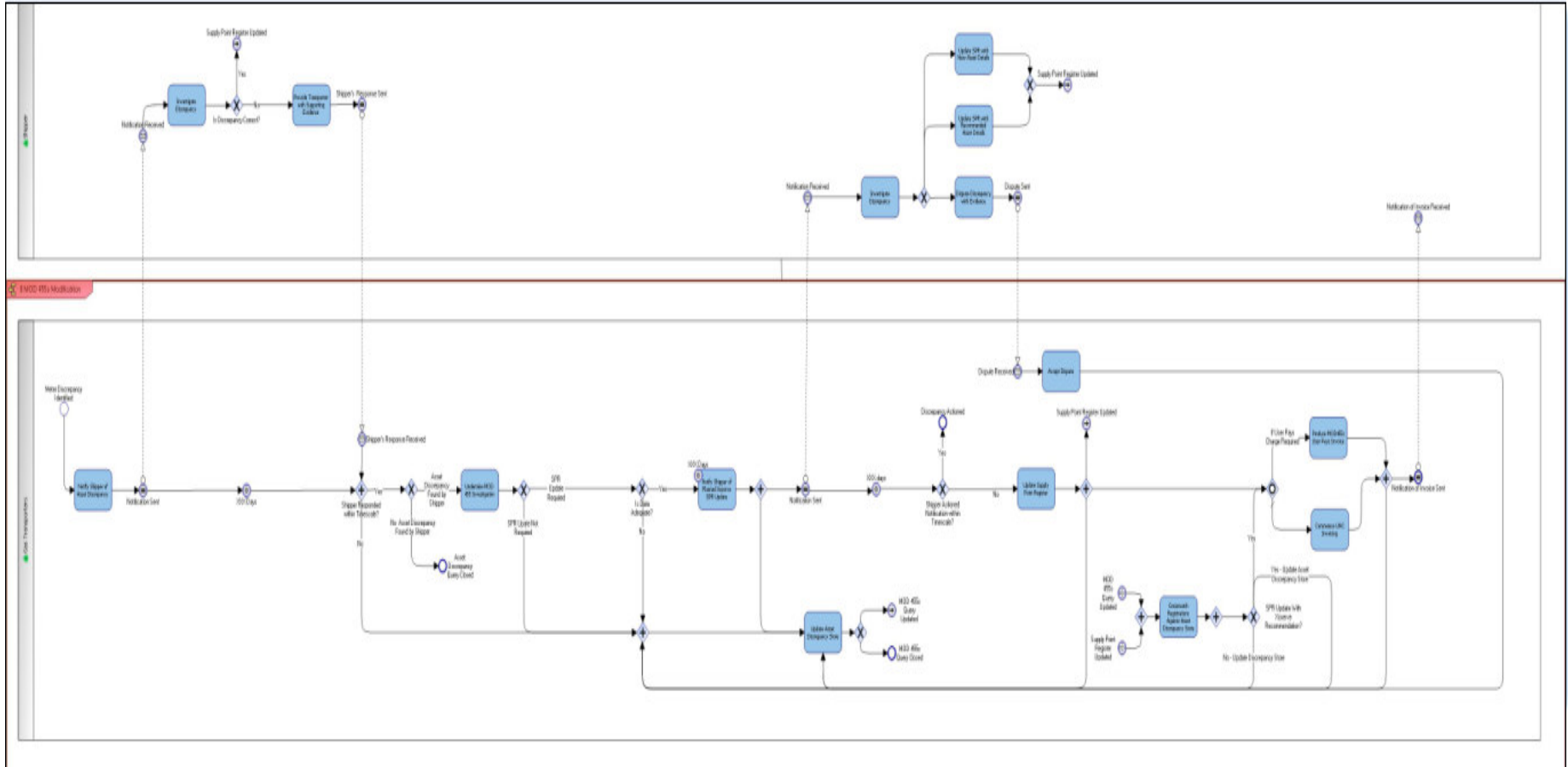

respect > commitment > teamwork

## Other Sample Processes

- GSR – Safety Visit
  - Meter removed from our system.
  - Safety visit one year later confirms meter at site does not correspond to Sites & Meters.
- ISO – Isolation Request
  - Network visit identifies gas service is live and meter information recorded on Sites & Meters is not reflective of site.

**xserve**



respect > commitment > teamwork

# GSR – Gas Safety Regulations

Sample	Removed MTR	Reported Mtr On site	Removed Date	In Ownership	Withdrawal Date
1	6(nnn)04	6(nnn)04s	21/07/2010	NO	02/08/2010
2	001(nnn)10	001(nnn)10	15/02/2012	YES	
3	00(nnn)57	G4W(nnnnnnnn)802	08/07/2012	YES	
4	G4A(nnnnnnnn)701	G4K(nnnnnnnn)1201	10/05/2012	YES	
5	4(nnn)61	G4A(nnnnnnnn)101	10/04/2012	YES	
6	G4A(nnnnnnnn)901	G4A(nnnnnnnn)901	13/07/2012	NO	21/04/2013

➤ **June 2013 recorded Visits:-**

- **181 – Same meter found on site**
- **187 – Different meter found on site**

\* (n) – Partial Meter Serial Number quoted to retain anonymity of data

**Xserve**



respect > commitment > teamwork

# Potential Volume Of Meter Misalignment

- **A selection of industry annual read rejections**

REJECTION REASON	NUMBER OF REJECTED READS
Meter Serial Number is for a Previous Meter	173,049
Meter Serial Number on the Read does not Match that held by Transco	537,926
Meter was Removed on the Read Date provided	53,653

- **RGMA rejections 1<sup>st</sup> Aug 2012 – 31<sup>st</sup> July 2013**

- **Rejected ONJOBS – 115,071**
- **Rejected ONUPDs – 88,31**